

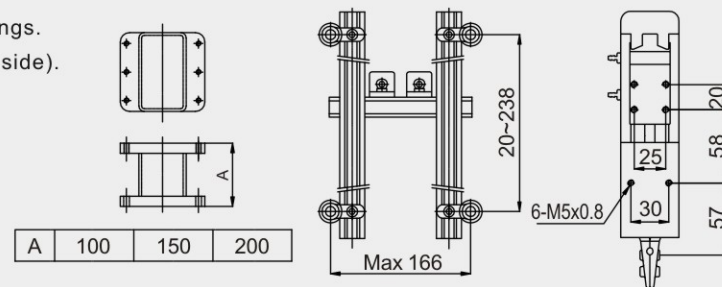

Model No.		Dry Cycle (sec.)		I.M.M. Range (Tons)	Vertical Stroke (mm)	Net Weight (Kgs)	Air Consumption (l / Cycle)
		Take-Out	Cycle				
YS450	Standard Model	0.6	3.1	25~150	450	33	9
YST450	With Twist					33.5	9.2
YSTV450	With Twist & Vacuum					34	15
YS550	Standard Model	0.7	3.2	60~180	550	33.5	10
YST550	With Twist					34	10.2
YSTV550	With Twist & Vacuum					34.5	16
YS650	Standard Model	0.8	3.4	120~250	650	34	11
YST650	With Twist					34.5	11.2
YSTV650	With Twist & Vacuum					35	17
YS750	Standard Model	1.0	3.8	200~350	750	34.5	12
YST750	With Twist					35	12.2
YSTV750	With Twist & Vacuum					35.5	18
YS850	Standard Model	1.2	4.0	300~450	850	35	13
YST850	With Twist					35.5	13.2
YSTV850	With Twist & Vacuum					36	19

### Comments:

- 1.YSTV-series:Fitted with vacuum generator and vacuum fittings.
- 2.Adjustable Swing Angle:60°~90° (To operator's side or rear side).
- 3.Adjustable Gripper Rotation Angle:60°~100°
- 4.Strip Stroke:100 mm
- 5.Effective Payload:4kg
- 6.Compressed Air Pressure:4~6kg / cm<sup>2</sup>
- 7.Power Consumption:Approximately 40VA
- 8.Operation Voltage:1 ∅ AC220V



### YSxxx

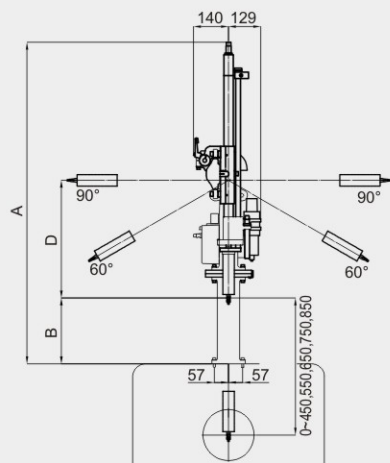

Model No.	YS450	YS550	YS650	YS750	YS850
A	1065~1265	1165~1365	1265~1465	1365~1565	1465~1665
B	115~315	115~315	115~315	75~275	75~275
C	1088~1288	1188~1388	1288~1488	1388~1588	1488~1688
D	421~621	421~621	421~621	461~661	461~661

### YSTxxx & YSTVxxx

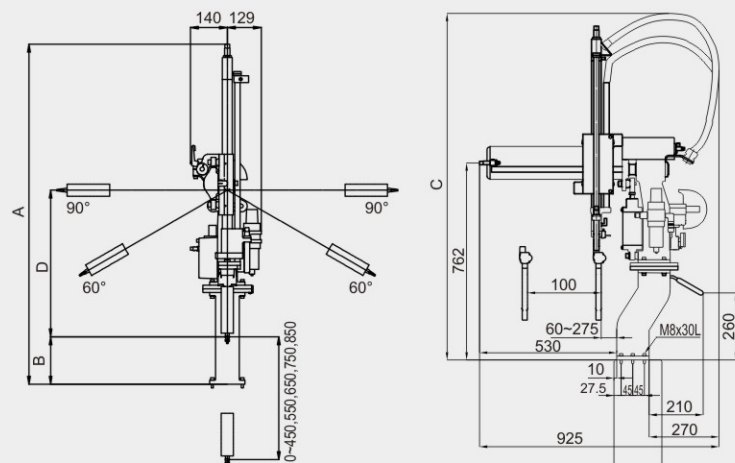

Model No.	YST(V)450	YST(V)550	YST(V)650	YST(V)750	YST(V)850
A	1065~1265	1165~1365	1265~1465	1365~1565	1465~1665
B	30~230	30~230	30~230	0~190	0~190
C	1088~1288	1188~1388	1288~1488	1388~1588	1488~1688
D	506~706	506~706	506~706	546~736	546~736



No. 10, Keyuan 3rd Rd., Situn District, Taichung City 407, Taiwan (R.O.C.)  
 Tel: 886-4-23550219 Fax: 886-4-23550218  
 E-mail: sales@apexrobot.com  
 website: www.apexrobot.com

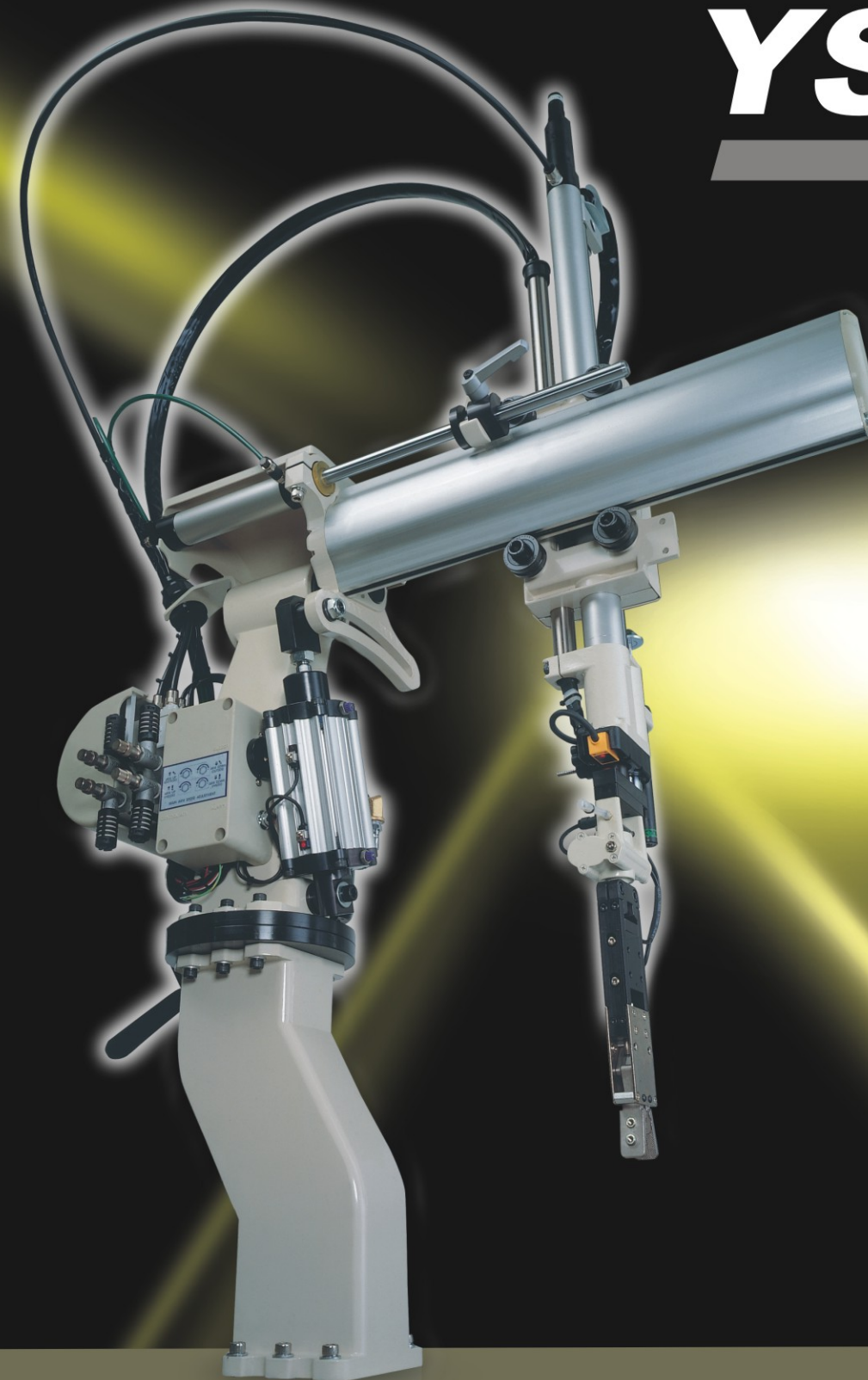

# YS Series

## Swing-Arm

# Speed. Performance. Quality

**Rapid cycle time, Rapid payback.  
High quality, low maintenance.  
Easy to install and operate.**

## Features.

01. Rigid constructed modular sections. Virtually maintenance and trouble-free.
02. Individual movement and speed adjustment.
03. Separated control unit to avoid hustle environment.
04. Ten standard sequences and ten teachable sequences.
05. Robot status and error message will display on pendent screen.
06. Incorrect or unsafe motion cannot be accepted by the program or will showing warning message.
07. SPI and EUROMAP interface.
08. Re-definable HOME position for Core-Pull operation.

## Programming.

01. Quick start with emergency stop.
02. Quality inspection program with counter setting.
03. Incomplete injection detection with counter setting.
04. Total injection cycle counter setting.
05. Test mold counter setting.
06. Alarm frequency and timer setting.
07. Motion and timer delay setting.
08. Reject parts detection with counter setting.
09. Spray counter setting.
10. Two spare output, one spare input.

## Optional Accessories.

01. Third mold plate movement detector.
02. Standard SPI or EUROMAP plug.
03. End of the arm tooling accessories.



Slimmer gripper design for tight mold open access.

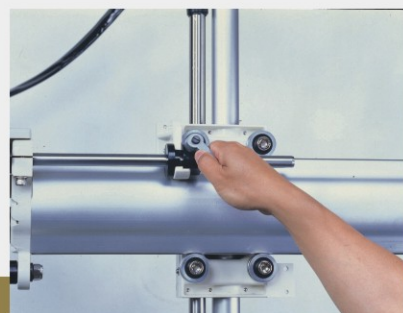

Tool-free adjustment on kick stroke.



Swing out direction and angle adjusted with one screw.

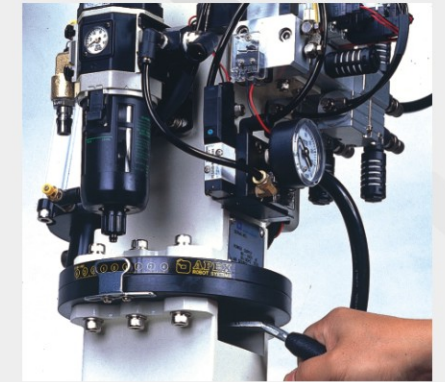

Simple base pivoting for ease of mold change.

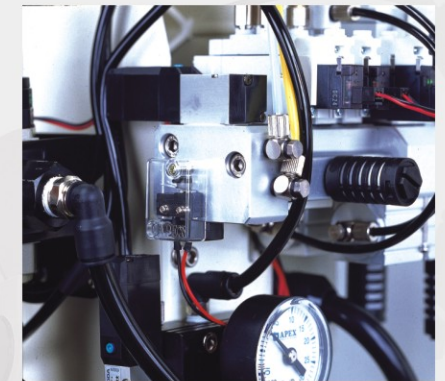

Patented pressure differential verification system. Reliable and maintenance free.

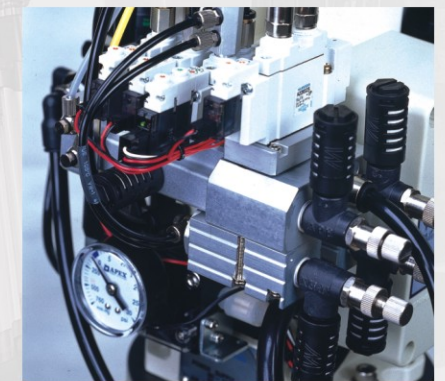

Centralize pneumatic control unit. Fast reaction and durable.